

ICC-ES Legacy Report

NER-598*

Reissued June 1, 2006

This report is subject to re-examination in one year.www.icc-es.org | (800) 423-6587 | (562) 699-0543

A Subsidiary of the International Code Council®

Legacy report on the 2000 *International Building Code*®, the 2000 *International Residential Code*®, the BOCA® *National Building Code*/1999, the 1999 *Standard Building Code*®, the 1997 *Uniform Building Code*™ and the 1998 *International One- and Two-Family Dwelling Code*®

DIVISION: 06—WOOD AND PLASTICS
Section: 06090—Wood and Plastic Fastenings

GO-BOLT, INC.
2250 OAKHILL DRIVE
DELAND, FLORIDA 32720-8681
888-734-4046
www.go-bolt.com

1.0 SUBJECT

Go-Bolt® Anchors

2.0 PROPERTY FOR WHICH EVALUATION IS SOUGHT

Structural - Uplift

3.0 DESCRIPTION

3.1 General

Go-Bolt is used to anchor wood stud walls and roof framing members to the foundation. Go-Bolt is a fabricated component consisting of a plastic sleeved threaded steel rod with a plastic stake for embedment in the ground. The concrete foundation is placed around the sleeved threaded rod with the top of the rod flush with the top of the concrete foundation. The top of the threaded rod is slotted for a screw driver. After the concrete is set, the threaded rod is raised above the foundation by using a screw driver. A bolt or coupler is then attached to the rod to anchor the wood stud wall to the foundation. The stake is a PVC pipe that has a foam sealant plug to keep ground water from entering and corroding the rod. Go-Bolt materials are listed in Section 3.2. The Complete Component Assembly is shown in Figure 1.

3.2 Materials

3.2.1 Washer: 3 inch by-3 inch by $\frac{1}{4}$ inch thick plate washer from steel hot rolled ASTM A 569.

3.2.2 Nuts: $\frac{1}{2}$ inch by 13 Hex Nut, width across flats = $\frac{3}{4}$ inch, thickness = $\frac{7}{16}$ inch, Type Grade 2, Low or Medium Carbon steel, SAE J995.

3.2.3 Embedment Sleeve: $\frac{1}{2}$ inch Thermoguard Potable Tubing, thickness 0.062 inches, ASTM D 3309.

3.2.4 Stake: $\frac{3}{4}$ inch PVC- SCH 40, PVC 1120, Type 1, Grade 1, wall thickness 0.113 inches, ASTM D 1785.

3.2.5 Coupler: $\frac{1}{2}$ inch - 13 by $1\frac{3}{4}$ inch, Grade A Carbon Steel, ASTM A 563 Grade A.

3.2.6 Threaded Rod: ASTM A 36 and ASTM A 307 Grade C $\frac{1}{2}$ inch - 13, 1008 Low Carbon Steel, roll thread diameter 0.476 inches, tensile strength of 84,700 psi, minimum yield stress 60,000 psi, zinc plating ASTM B 633.

3.2.7 Stake Sealant: Enerfoam, UL File R14540.

3.3 Design Loads - Uplift

Go-Bolts have an allowable design Uplift load of 3,990 pounds when using Southern Pine top plates and 3725 pounds when using Spruce-Pine-Fir top plates. Go-Bolts embedded into masonry lintels or bond beams shall have an allowable design Uplift load of 3,860 pounds when using Southern Pine top plates and 3,725 pounds when using Spruce-Pine-Fir top plates. The Go-Bolts are installed continuous from foundation to wood double top plates on wood stud or masonry walls, see Sections 4.2 and 4.3, and Figure 1. The allowable design load shall not be increased for duration of load.

The capacities noted above for Go-Bolt anchors are not intended to represent the capacity of framing systems or masonry walls connected to the Go-Bolt anchors. The design of framing and other elements within the load path of the Go-Bolt anchors is the responsibility of the design professional, and shall be performed in accordance with the applicable code, considering loads, displacements, shrinkage, etc. The design of wall top plates receiving uplift load and distributing it to the Go-Bolt anchors shall consider both deflection and strength limit states, including combined axial and flexural stress for cases where the wood top plate(s) also acts as a drag strut or collector, and shall also consider geometric compatibility. A positive method to resist torsional rotation and cross-grain flexure of the top plates due to offsets between the point of load application (e.g., hurricane ties at the sides of the top plates) and load resistance (e.g., anchors at the center of the top plate) shall be provided where such conditions exist; and calculations in accordance with principles of mechanics shall be used to determine the demand on connections used to resist top plate torsion.

***Revised July 2010**

4.0 INSTALLATION

4.1 General

Go-Bolts shall be installed in accordance with the manufacturer's published installation instructions and this report. See Figure 1.

The manufacturer's published installation instructions and this report shall be strictly adhered to and a copy of these instructions shall be available at all times on the job site during installation.

The instructions within this report govern if there are any conflicts between the manufacturer's published instructions and this report.

4.2 Foundations

Go-Bolts shall be embedded 6 inches into concrete foundations that are minimum 10 inches thick with a minimum compressive strength of 2,500 psi. The bolts shall have a minimum edge distance of 2 inches and shall be spaced as required to resist wind uplift load. The foundations shall be designed to resist the design loads determined in accordance with Chapter 16 of the applicable *Code*.

4.3 Wall Construction

Wood framed walls anchored with Go-Bolt shall be constructed of either Spruce-Pine-Fir No. 2, specific gravity of $G = 0.42$ or Southern Pine No. 2, specific gravity of $G = 0.55$, minimum 2 inch nominal thickness. Masonry walls shall be constructed of ASTM C 90 concrete masonry units, CMU. Wood stud and masonry walls shall have minimum double top plates of 2 by 4 wood, either Spruce-Pine-Fir No. 2, specific gravity $G = 0.42$ or Southern Pine No. 2, specific gravity of $G = 0.55$. The wood and masonry walls shall be designed to resist the design loads determined in accordance with Chapter 16 of the applicable *Code*.

5.0 IDENTIFICATION

Each component of the Go-Bolt[®] Anchor system covered by this report shall be labeled with the manufacturer's name/and or trademark, address, the product name, and this ICC-ES legacy evaluation report number, NER-598.

6.0 EVIDENCE SUBMITTED

6.1 Manufacturer's descriptive literature, specifications, and published installation instructions.

6.2 Specifications for threaded rod, Vulcan Threaded Products, Inc., October 14, 1994, December 2, 1994, December 5, 1994, 6-29-98 and March 22, 2001 signed by Jeff Hayes.

6.3 Letters from B-Line Systems, Inc., Allowable Loads for B655 Rod Coupler and B104 Right Angle Support, December 1, 1994, and December 5, 1994, signed by Robert D. Oliver. Specifications and testing for Coupler and Angle Bracket, B-Line Systems, Inc.; Coupler, M002, 04/17/90; Angle Bracket, M010, Rev. C, 04/13/94.

6.4 Summary report with materials specifications, engineering drawings, ultimate and allowable test values, signed and sealed by Allen A. Davis, P.E., 10/26/98. Revised 12/21/98.

6.5 Test reports, uplift load test under ASTM D 1761, Product Testing, Inc., signed by Robert K. Prophet and signed and sealed by C.R. Caudel, P.E.:

6.5.1 Go-Bolt embedded in concrete, Job #98-1617, February 13, 1998.

6.5.2 Go-Bolt attached to double wood top plates SYP and 2 by 2 by $\frac{1}{4}$ inch square washer, Job #98-1642, March 6, 1998.

6.5.3 Go-Bolt attached to double top plates SPF and 2 by 2 by $\frac{1}{4}$ inch square washer, Job #98-1898, September 18, 1998, Proposal No. 307.

6.5.4 Go-Bolt in masonry bond beam with 2,500 psi concrete, Job #98-1897, September 15, 1998, Client P.O. #307.

6.6 Test reports on tensile testing, Product Testing, Inc., signed by Robert K. Prophet and signed and sealed by C.R. Caudel, P.E.:

6.6.1 All threaded rod materials, Job #97-1551, December 24, 1997.

6.6.2 Nut, coupler and rod material, Job #97-1539, December 22, 1997.

6.6.3 Anchor Rod with coupler nut, Job #98-1753, May 27, 1998.

6.6.4 Letter report on number of threads engaged in coupler, May 27, 1998.

6.7 Test report on shear test of rod material, Product Testing, Inc., Job #98-1671, March 7, 1998, signed by Robert K. Prophet, and signed and sealed by C.R. Caudel, P.E.

7.0 CONDITIONS OF USE

The ICC-ES Subcommittee for the National Evaluation Service finds that the Go-Bolt[®] Anchor System described in this report complies with or is a suitable alternate to that specified in the 2000 *International Building Code*[®], the 2000 *International Residential Code*[®], the BOCA[®] *National Building Code/1999*, the 1999 *Standard Building Code*[®], the 1997 *Uniform Building Code*[™] and the 1998 *International One- and Two-Family Dwelling Code*[®] subject to the following conditions:

7.1 This Evaluation Report and the installation instructions, when required by the code official, shall be submitted at the time of permit application.

7.2 Design loads on the Go-Bolt shall be determined in accordance with Chapter 16 of the adopted *Code*.

7.3 Design of the framing systems (wood and/or masonry) is the responsibility of the design professional, and must be performed in accordance with the applicable code, considering all of the design considerations given in Section 3.3 of this report.

7.4 Each package of Go-Bolt components shall contain the manufacturer's published installation instructions.

7.5 In jurisdictions that have adopted the *Standard Building Code* and *SSTD 10-99*, the following Conditions of Use apply:

7.5.1 Go-Bolt connectors that are exposed directly to weather or subject to salt corrosion in coastal areas, as determined by the building official, shall be galvanized in accordance with 302.1.3 of *SSTD 10-99*.

7.5.2 When using *SSTD 10-99*, the design loads listed in the standard shall not exceed those recommended by the manufacturer as shown in Section 3.3.

7.6 Go-Bolt connectors shall not be used in grouted masonry lintels or bond beams. Go-Bolt connectors shall be permitted to be installed in formed concrete lintels or bond beams used as part of a masonry wall. The concrete lintels or bond beams shall have a minimum compressive strength of 2,500 psi. Design loads for the connectors shall be as noted in this report.

7.7 This report is subject to periodic re-examination. For information on the current status of this report, contact the ICC-ES.

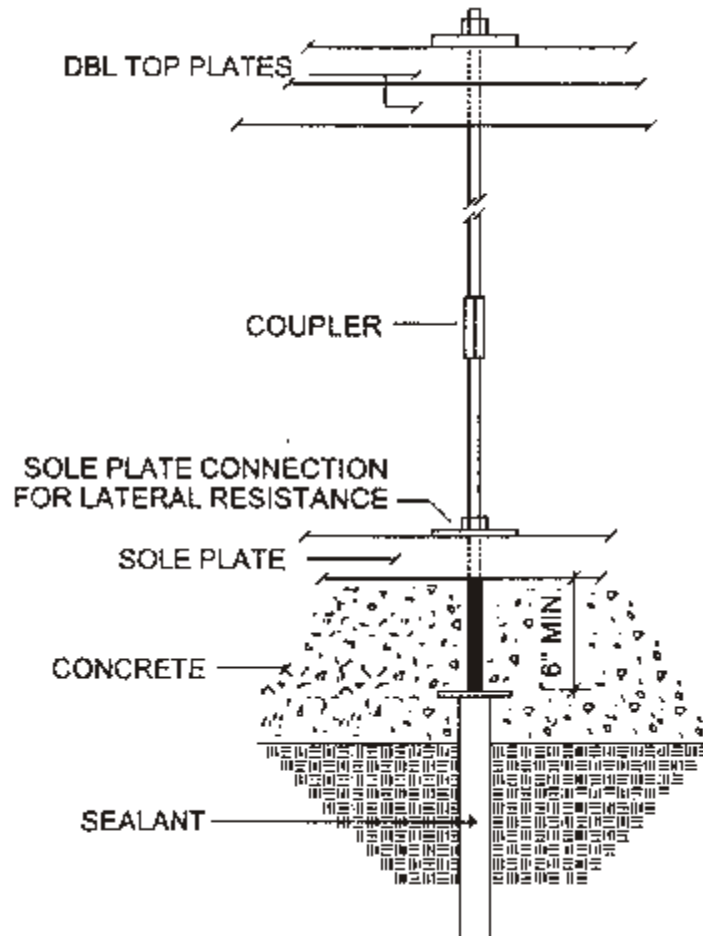

FIGURE 1